

**OVERHEAD BRACED**

**USE THESE SIZES FOR DRILLING** (ALL FASTENERS ARE T27 PIN HEAD TORX)

#9 drill for #14 x 5/8" sheet metal screws

1/4" carbide drill for conical anchors

1/4" high speed drill for hinge and stop/keeper thru bolts

**1 INSPECTION**

The components for this project have been custom fabricated. They were inspected at the factory and all workmanship is guaranteed. Before beginning work, the units should be inspected. If damage occurred in transit, report immediately to the freight company or other agencies that may have caused the damage.

**2 LAYOUT**

- Review the layout drawings and package lists that have accompanied this job.
- Establish and mark pilaster center line from back wall.
- Establish and mark panel center lines for wall brackets.
- Establish pilaster floor fastener locations from side wall according to shop drawings. (Note floor fasteners are located 1" from each edge of pilaster).
- Mark wall bracket holes using brackets as templates.
- Drill holes for wall brackets and floor fastenings of appropriate size for particular fastening devices supplied.

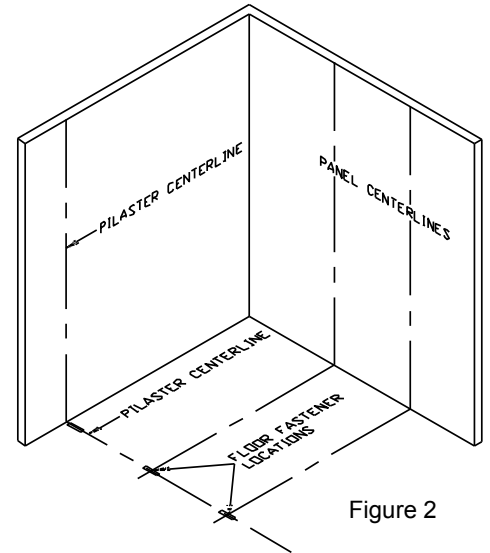

Figure 2

**3 WALL BRACKETS & FLOOR BRACKETS**

- Before proceeding, confirm that backing of wall and floor is adequate to support secure mounting of the toilet compartments.
- Insert shields or other floor fastening devices. Position shoe clips and mounting forks over shields and secure loosely with screws.

**4 POSITION PANEL**

- Place panel on a support 12" above the floor.
- Set it into wall brackets, but do not fasten panel at this time.

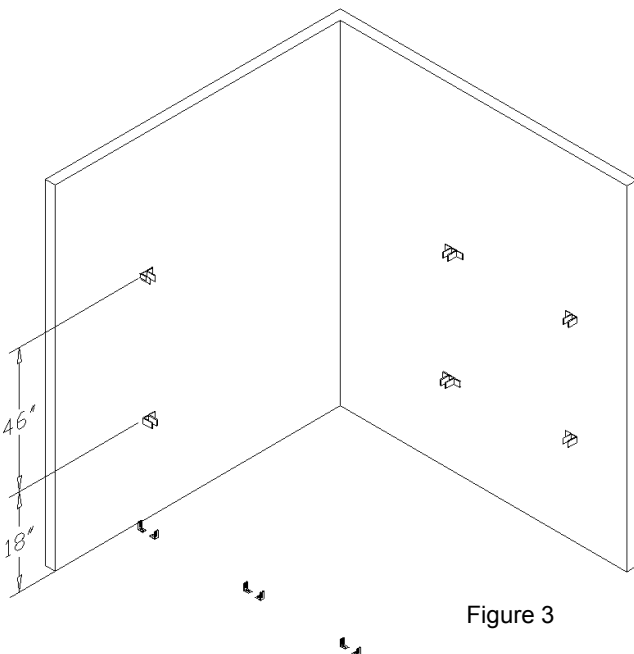

Figure 3

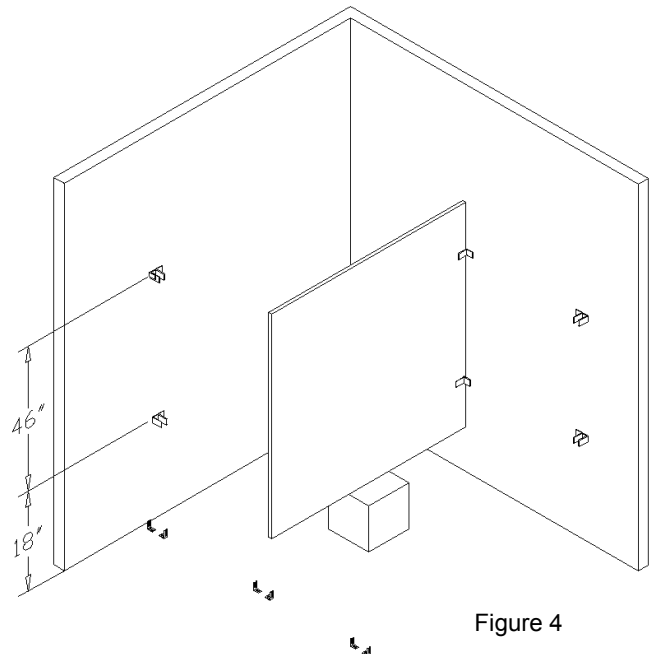

Figure 4

## OVERHEAD BRACED

### 5 PILASTER PREPARATION

- Align U-brackets in position on rear of pilasters. Refer to layout drawings.
- Fasten U-brackets to pilasters with screws.
- Pilasters at wall do not require U-brackets, but should be prepared for wall (and floor fastening) as required by compartment layout. If floor fastening is omitted, three wall brackets should be used.

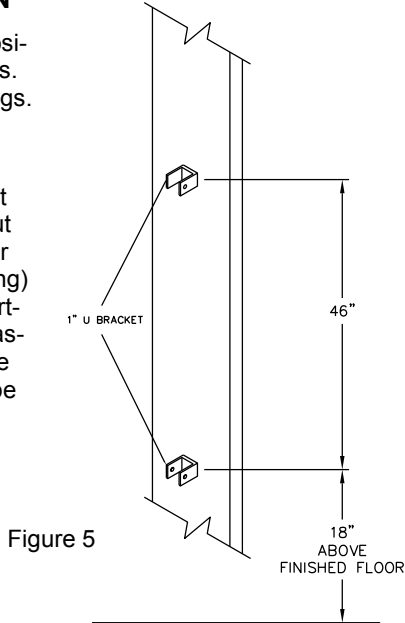

Figure 5

### 6 INSTALL PILASTER

- Slide stainless steel shoe carefully over mounting end of pilaster and leave approximately 5" above end.
- Place pilaster on mounting forks and fasten loosely with screws at pre-drilled locations at each side.

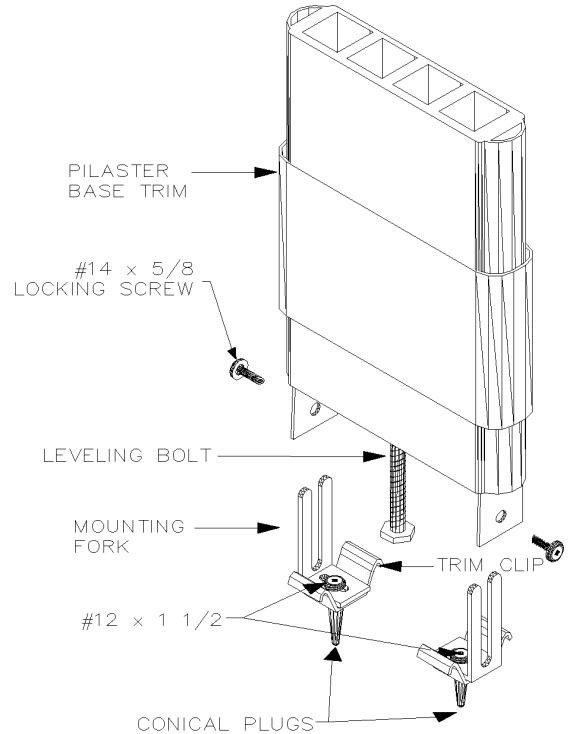

Figure 6

### 7 SECURING PILASTERS TO PANELS

- Pilasters must be both plumb and level.
- Plumb pilaster and fasten pilaster to panel using the sheet metal screws provided.
- Establish bottom door openings by adjusting pilaster to desired position and tightening screws.

### 8 HEADRAIL AND PANEL FASTENING

- Level headrail from one compartment to the next by adjusting the jack leveling bolt on the mounting at the bottom of pilaster.
- Tighten locking screws at sides of pilaster mounting bracket.
- Establish top door openings by mounting headrail and secure with screws on inside of pilaster.
- Slide stainless steel shoe down to floor level, firmly engaging shoe clips.
- Place a carpenter's level on top of panel and wedge out from rear wall until level. Attach panel to wall brackets using the sheet metal screws provided. Continue procedure for all panels.
- Remove panel support device.
- To insure rigidity, install headrail between end pilaster and wall by securing "F" brackets above end panel to surface of headrail and on opposing wall surface.

Figure 8

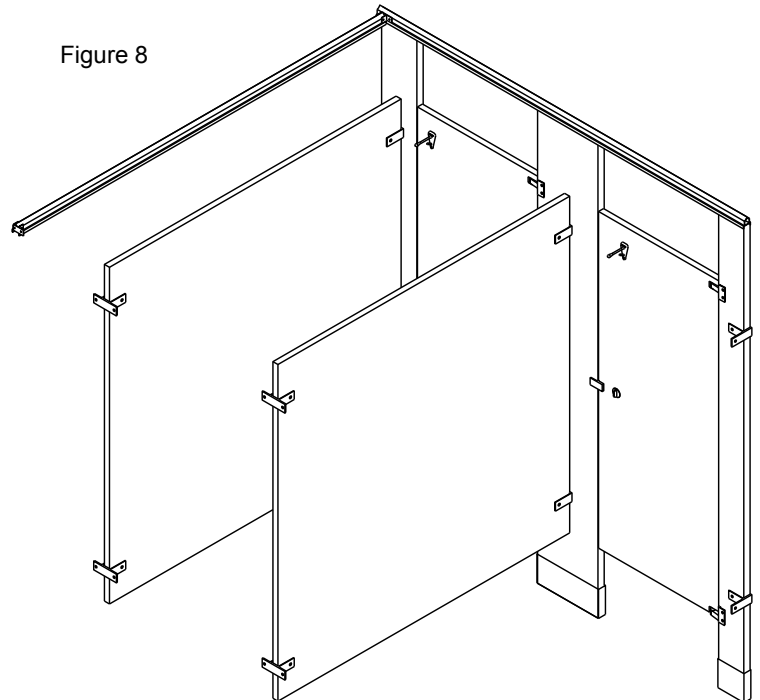

9

**DOOR ASSEMBLY AND HANGING**

- a. Attach top and bottom hinge brackets to pilaster with thru bolts (4-total). If pilasters were not pre-drilled at the factory, use dimensions shown in Figure 9A as a drilling ( $\frac{1}{4}$ " bit) guide.
- b. Assemble cam pintle, external tooth washer, internal tooth washer, and  $\frac{1}{2}$ " hex nut to the bottom hinge bracket as shown in Figure 9A and hand-tighten (to be wrench-tightened later).
- c. Insert box cam into bottom door casting as shown in Figure 9A, with short key pointing toward hinge side (edge) of door.
- d. Set door onto bottom hinge cam pintle. Bring door up so the top hinge casting is in line with the top hinge bracket as shown in Figure 9A. Insert the top hinge pintle and tap it down so it's flush with the top of the door.
- e. Set resting position of door. Hold door firmly in desired resting position (typically 20 degrees open for inswing doors and closed for outswing doors and all accessible compartment doors, regardless of swing) and wrench-tighten the  $\frac{1}{2}$ " hex nut under bottom hinge bracket.
- f. Mount external plate and knob. Remove clear plastic retainer holding spring washer in place on the post of the external plate. Insert the external plate into door as shown in Figure 9B, with the shorter post inserted into the upper pocket of the internal latch mechanism. Mount the knob/handle on the inside of the door and engage it with both the center post and the shorter, off-center post of the external plate. Insert  $\frac{1}{2}$ " shoulder screw with blue tip through the knob/handle and tighten until snug. Check for proper operation of knob and latch pin before final tightening.
- g. Locate strike/keeper on the latch-side pilaster so the latch pin engages with it when the door is closed. Drill ( $\frac{1}{4}$ " bit) mounting holes and secure strike/keeper to pilaster using thru bolt (1), with black rubber bumper facing out for outswing doors and in for inswing doors.
- h. Mount coathook/bumper near center of door and 34"- 48" above the floor with #10 x  $\frac{3}{4}$ " sheet metal screws (drill holes with  $\frac{1}{8}$ " bit).
- i. Mount door pulls with 1- $\frac{1}{4}$ " step bolts (drill holes with  $\frac{1}{4}$ " bit) to both sides of all outswing doors and accessible compartment doors, near the latch and no more than 48" above floor.
- j. Mount wall bumper for outswing doors that are hinged next to a wall using conical anchor (drill hole with  $\frac{1}{4}$ " bit) and 1" sheet metal screw.

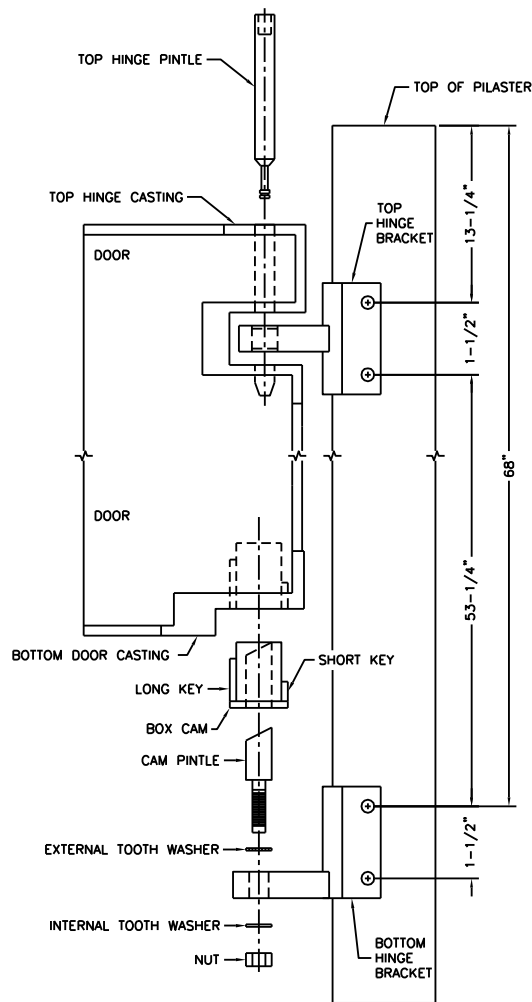

Figure 9A

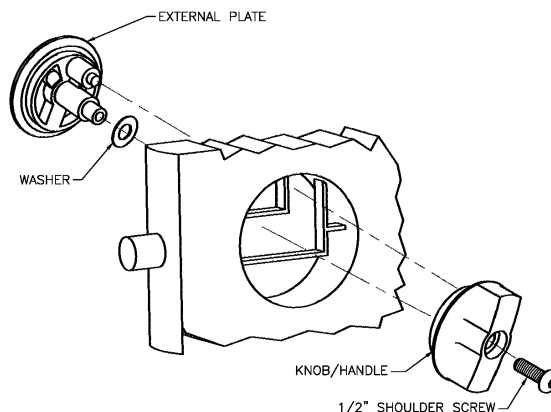

Figure 9B

**OVERHEAD BRACED**

**10 CARE AND MAINTENANCE OF TOILET PARTITIONS**

In order to provide toilet partitions with the proper care and maintenance, the following instructions must be followed.

- a. All surfaces must be kept clean with water and a mild soap solution.
- b. Water left on units for extended periods will damage surface. The finish must be wiped dry following cleaning.
- c. In high humidity areas, the room must be properly ventilated.
- d. Complete Care & Maintenance instructions are available at [www.asi-accuratepartitions.com](http://www.asi-accuratepartitions.com).

**11 PRE-PACKAGED HARDWARE KITS**

For your convenience and ease of installation, this shipment contains pre-packaged hardware for all standard toilet partition layouts. The packages are numbered as follows and should be used as shown on the diagram.

Figure 11

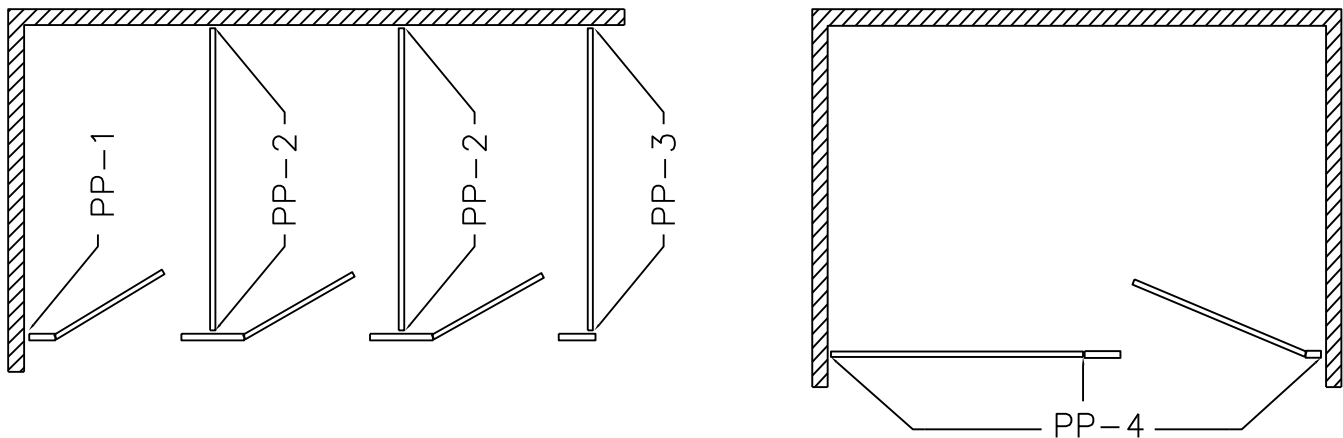

- PP-1 Hardware Pre-Pack #1 - Pilaster to Wall
- PP-2 Hardware Pre-Pack #2 - Intermediate Pilaster to Panel to Wall
- PP-3 Hardware Pre-Pack #3 - End Pilaster to Panel to Wall
- PP-4 Hardware Pre-Pack #4 - Complete Alcove Hardware

**ASI Accurate Partitions**